

Grounding kit Installation Description

Assembly Steps:-

- (1) Push the plastic base into the slot at the bottom of the heat sink of the machine by pressing the right arrow as shown in the figure.
- (2) Install the metal pressure plate and lock 6 fixing screws.

Disassembly Steps:-

- (1) Remove 6 fixing screws and remove the metal pressure plate.
- (2) Pull the plastic base from the bottom of the machine's heat sink by pressing the left arrow as shown in the figure.

Note: JN5-DIN-S01 (Din-rail kit mode number) including the following parts:

1. Plastic base
2. Metal pressure plate
3. Fixing screws: M3x6

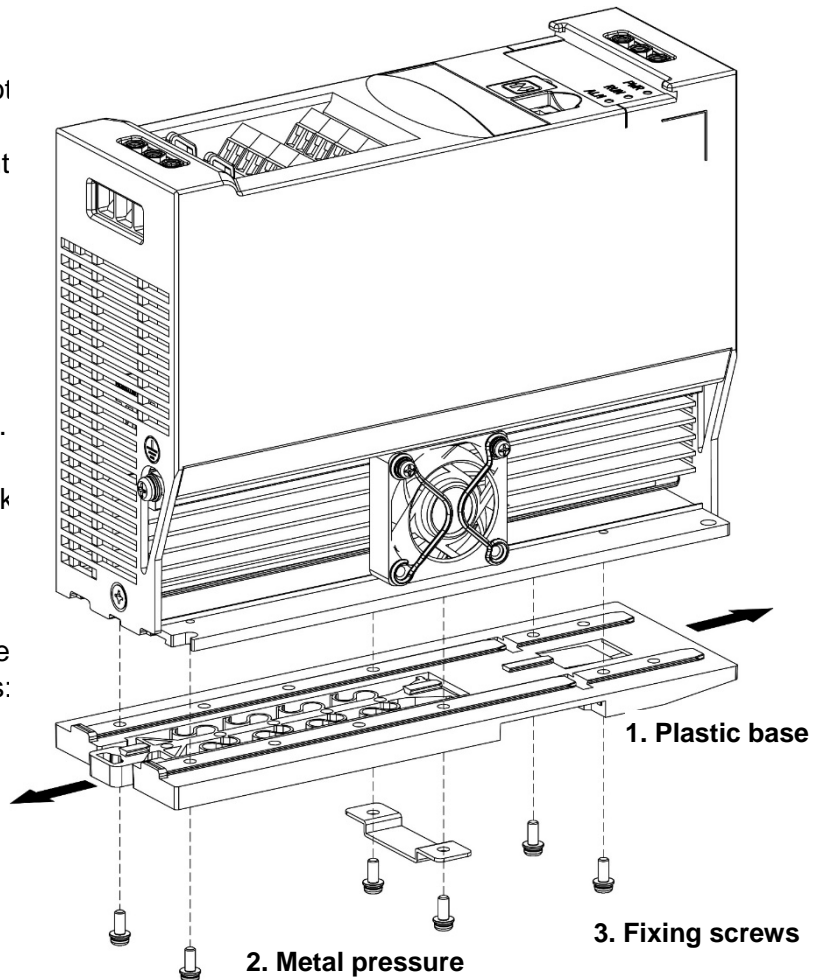

Din Rail Mounting & Dismounting as shown in the diagram below. Use a 35mm Din Rail as example.

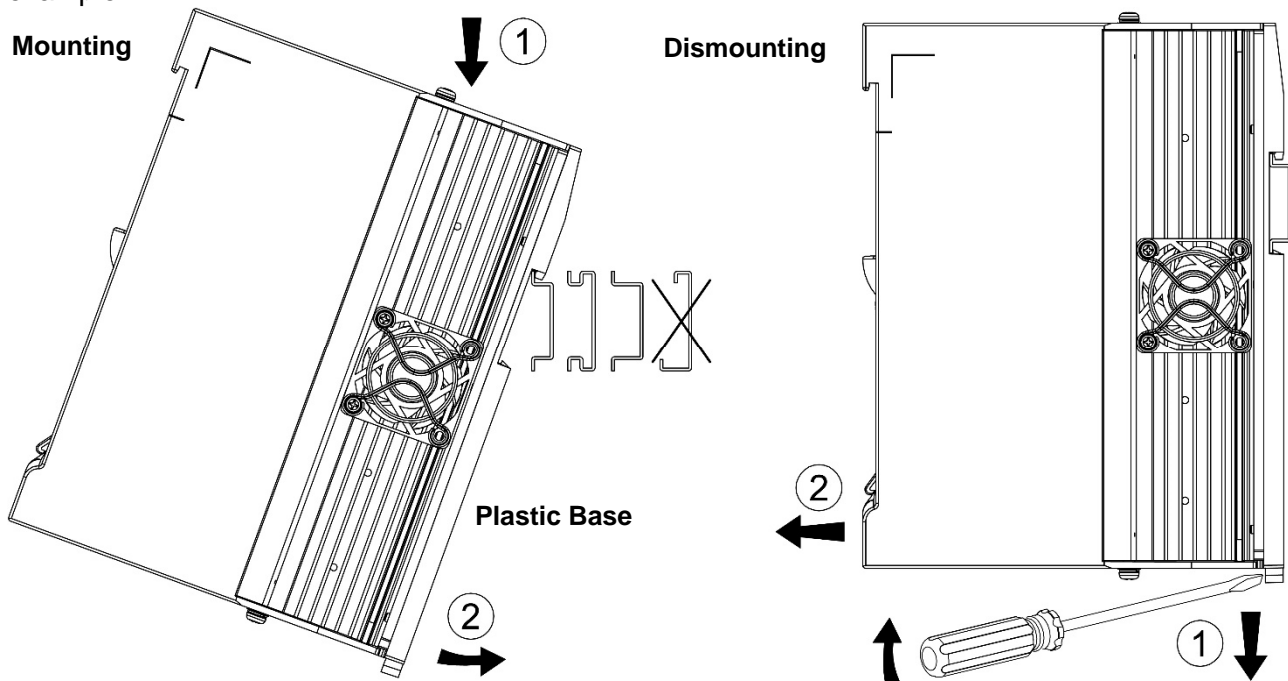

Din rail 安裝方式

安裝步驟：

- (1) 將塑膠底座按下圖示右箭頭
推入機器散熱座底部卡槽，
- (2) 安裝金屬壓板，
並鎖上 6 顆固定螺絲。

解除安裝：

- (1) 拆除 6 顆固定螺絲
並移除金屬壓板，
- (2) 將塑膠底座按下圖示左箭頭
從機器散熱座底部抽出。

註：配件另購 (型號：JN5-DIN-S01)

- 含以下附件：
1. 塑膠底座
 2. 金屬壓板
 3. 鎖固螺絲: M3x8

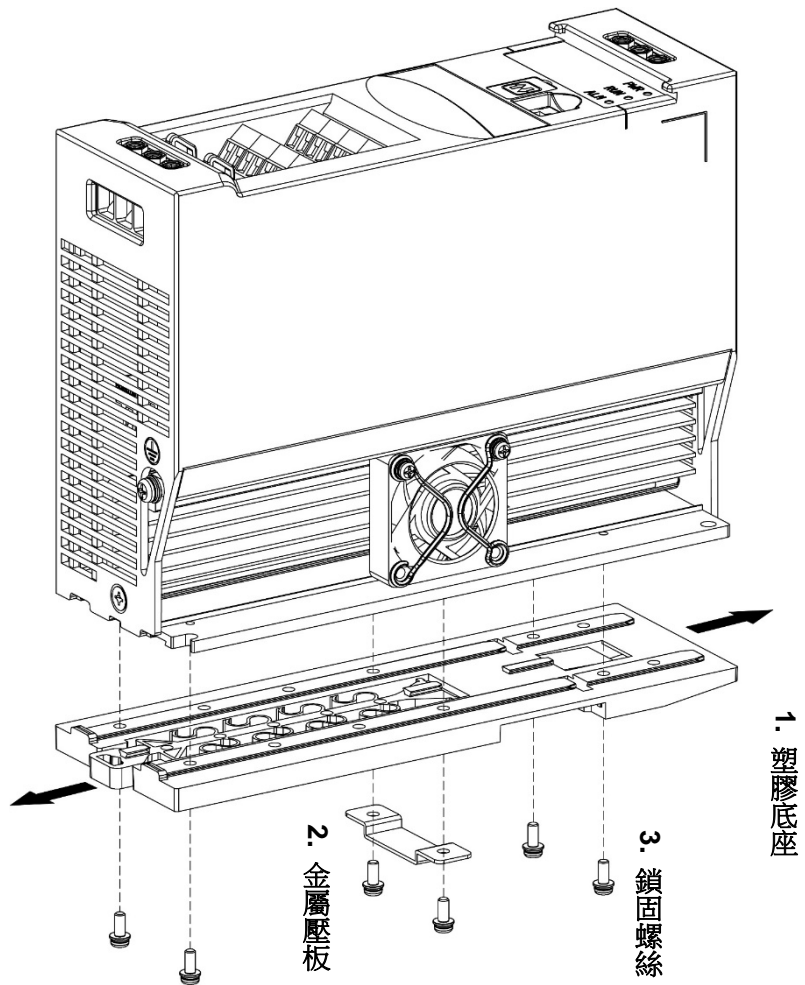

含 Din rail 之驅動器於滑軌之安裝及移除圖示說明如下：以 35mm 寬之 Din rail 為例

